

Casting Examples

SECTION

9

Aluminum	9-2	Zinc	9-14
Pistol Frame	9-2	Knot	9-14
Rocker Arm	9-2	Bracket	9-14
Right/Left Hand Bracket	9-2	Faucet Handle	9-14
Endbell	9-3	Connector	9-15
Engine Base Bracket	9-3	Kitchen Faucet Hub	9-15
Water Passage	9-3	Fuel Fitting	9-15
Heat Sink Front & Back	9-4	Reverse Valve Casket	9-16
Chassis	9-4	Casket Arm	9-16
B Pillar	9-4	Display Frame Component	9-16
Trimmer Deck Housing	9-5	Outside Cover	9-17
RFU Enclosure	9-5	Front Plate L-20	9-17
Impeller	9-5	Connector Housing	9-17
Lower Crankcase	9-6	Rearview Mirror Mount	9-18
Differential Carrier	9-6	Steering Wheel Ignition Lock Housing	9-18
Beta Crankcase Right & Left	9-6	Headlamp Visor	9-18
Scooter Monocoque Frame	9-7	Camera Bracket	9-19
Rear Wheel Drive Northstar Block Casting	9-7	ZA (Zinc-Aluminum)	9-20
Power Condition Module Chassis	9-7	Tool Housing & Components	9-20
MMC Brake Drum	9-8	Transmission Shift Selector Tube	9-20
AWD Clutch Housing	9-8		
RWD Transmission	9-8		
Magnesium	9-9		
Frame	9-9		
Head Node	9-9		
Fishing Reel	9-9		
Clutch Cover	9-10		
Camera Assembly	9-10		
Hand-Held Computer Housing	9-10		
Gear Case Housing Assembly	9-11		
Lock Housing	9-11		
Fairing Support Bracket	9-11		
Seat Back and Cushion	9-12		
Lift Gate Inner Panel	9-12		
Cross Car Beam for Instrument Panel	9-12		
Oil Tank	9-13		
SAWZALL Gear Case Assembly	9-13		

Casting Examples

Aluminum

Part Name: Pistol Frame
Application: 0.22 Caliber Pistol
Part Weight: 0.35 lbs.
Alloy: A380
Comments: Part was previously machined from stock. This is the first aluminum die casting used by Smith & Wesson.
Customer: Smith & Wesson

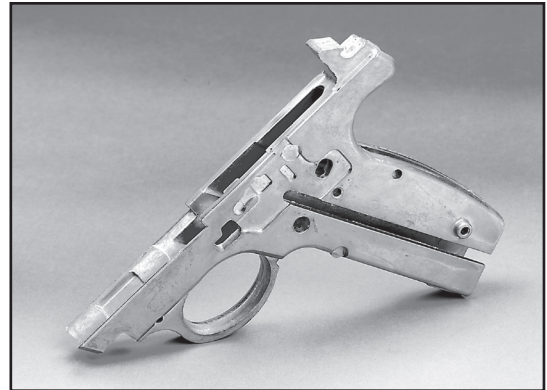

Aluminum

Part Name: Rocker Arm
Application: Honda Civic Engine
Part Weight: 0.48 lbs.
Alloy: 383
Comments: Process improvements and strict attention to detail resulted in cost savings on these high integrity, near porosity-free parts. The parts include a special "wear" insert chip and meet very tight specifications.
Customer: Honda of America Mfg., Inc.



Aluminum

Part Name: Right/Left Hand Bracket
Application: BRP Skidoo
Part Weight: 0.75 lbs.
Alloy: Aural-2
Comments: Part was previously made from low pressure permanent mold with extensive machining. High vacuum die casting created a heat treatable and weldable part for structural application, requiring minimal machining. Overall piece price reduction was on the order of 40%.
Customer: BRP Skidoo



Casting Examples

Aluminum

Part Name: Endbell

Application: Air Compressors

Part Weight: 0.85 lbs.

Alloy: 380

Comments: Major tooling and process improvements resulted in scrap reduction, increased cost savings, production and quality. Completed cast units highly competitive in the market against lower entry models produced using stamped steel.

Customer: Devilbiss Air Power Company

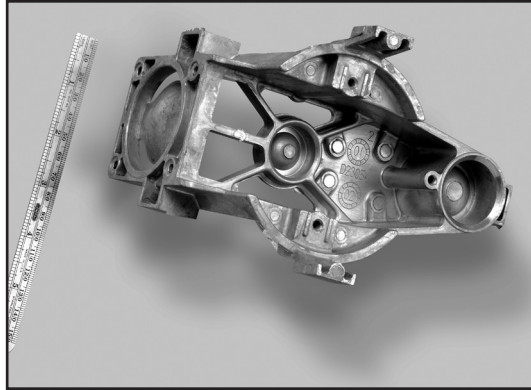

Aluminum

Part Name: Engine Base Bracket

Application: Honda Accord Engine

Part Weight: 6.2 lbs.

Alloy: ADC3SF jointly developed with Honda, compatible with SF36, Aural 2

Comments: Replacing a previously stamped, 16 piece part, the new part is 27 in. long, thin-walled, with screw bosses, eliminating the welding operation and reduced weight by 43.6%.

Customer: Honda



Aluminum

Part Name: Water Passage

Application: Honda Civic Engine

Part Weight: 1.4360 lbs.

Alloy: 383

Comments: The Water Passage hose mating surface is cast to specifications allowing the shipping of the part to the customer without any machining to the snout. This tight tolerance allows a cost savings to the customer. The customer saves the cost of machining for the snout, which is estimated at a 23% cost savings.

Customer: Honda of America Mfg. Inc.

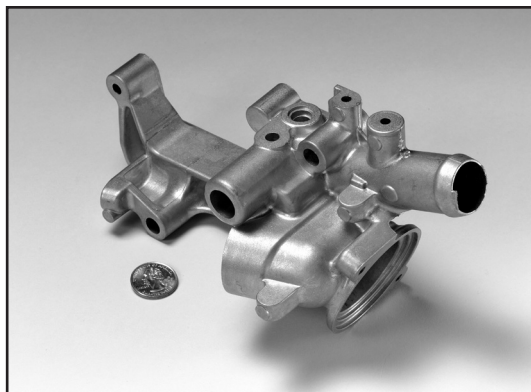

Casting Examples

Aluminum

Part Name: Heat Sink Front & Back
Application: Garmin G-1000
Flat Panel Flight Display
Part Weight: 1.91 lbs.
Alloy: 360
Comments: Parts are assembled to collect & disperse heat from an LCD unit. Converted from machined parts to die castings. Increased production rate & reduced piece part cost. First time use of aluminum heat sink for this type of application. 360 alloy was selected based on it's corrosion resistance which protects the assembly from oxidation & other corrosion resulting from frequent atmospheric changes experienced by components used in general aviation. Painting or coatings are not required & are ready for assembly upon arrival at customer location.

Customer: Garmin International

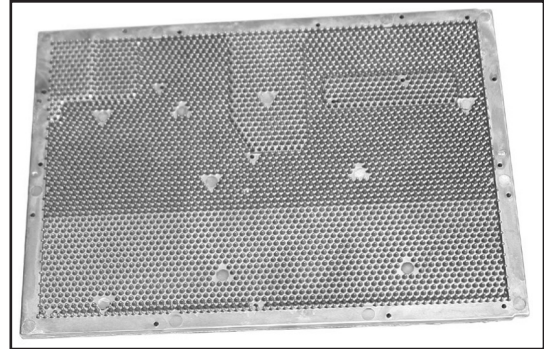

Aluminum

Part Name: Chassis
Application: Human Transporter
Part Weight: 8.2 lbs.
Alloy: 380
Comments: The casting is produced to net shape and meets strict specifications. True position tolerances on critical dimensions were reduced resulting in reductions in machining and substantial cost savings.

Customer: Segway

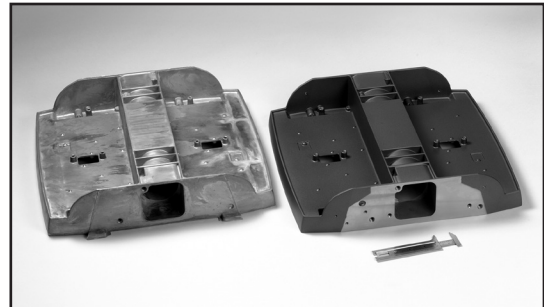

Aluminum

Part Name: B Pillar
Application: Automotive Structural Support
Part Weight: 9.2 lbs.
Alloy: 380
Comments: A new part cast for automobile body framing support application. Yields weight savings benefit over fabricated steel components.

Customer: —

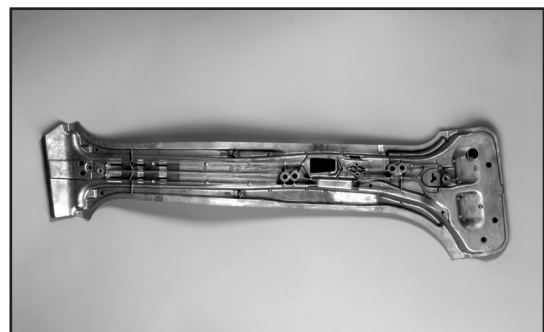

Casting Examples

Aluminum

Part Name: Trimmer Deck Housing

Application: Walk Behind Trimmer

Part Weight: 9.2 lbs.

Alloy: 380

Comments: As compared to a previous die casting design and tooling design, newly designed tooling allowed for scrap reduction (34%), cycle time reduction (52 sec.) and weight reduction (2 lbs.).

Customer: Garden Way, Inc.

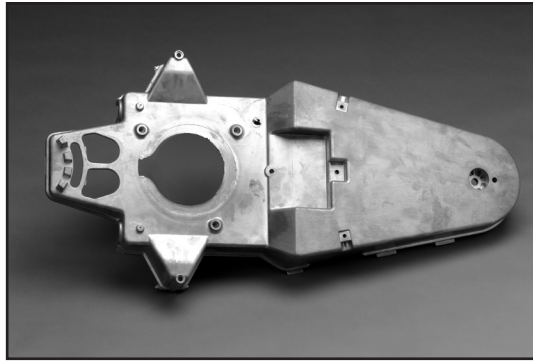

Aluminum

Part Name: RFU Enclosure

Application: Microwave Communications

Part Weight: 15.8 lbs.

Alloy: 413

Comments: Formerly produced as an investment casting. Provides heat dissipation and electrical conductivity. Die casting reduced lead time and machining requirements.

Customer: Harris Corporation, Microwave Communications Division



Aluminum

Part Name: Impeller

Application: Industrial/Commercial Blower

Part Weight: 10.29 lbs

Alloy: A380

Comments: Impeller used in industrial and commercial blowers. The application of the die cast part enabled the unit to operate at higher speeds, with less noise, while reducing the amount of secondary machining.

Customer: Ametek Rotron

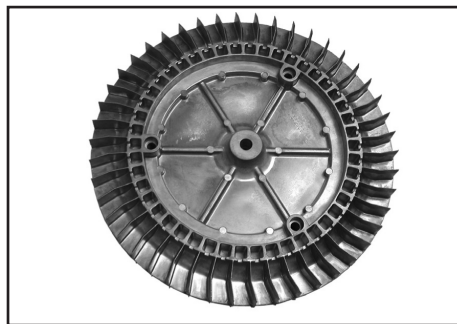

Casting Examples

Aluminum

Part Name: Lower Crankcase
Application: Motorcycle
Part Weight: 16.31 lbs.
Alloy: LM2 to JVM Specifications
Comments: Redesign of original T120, 1959 Bonneville high performance version of Triumph's 650cc twin. Eliminated costly secondary machining operations, additional engine parts and fully utilized the benefits of high pressure die casting process.
Customer: Triumph Motorcycles

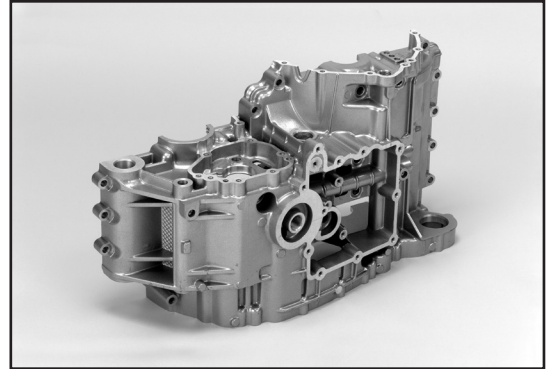

Aluminum

Part Name: Differential Carrier
Application: Independent Rear Suspension
Part Weight: 16.5 lbs.
Alloy: ADC-12 -T6 Heat Treatment
Comments: Past generation was an iron casting. First high volume squeeze casting used in an independent rear suspension axle carrier. Squeeze casting decreased weight by 22 pounds over cast iron process.
Customer: Visteon Corporation

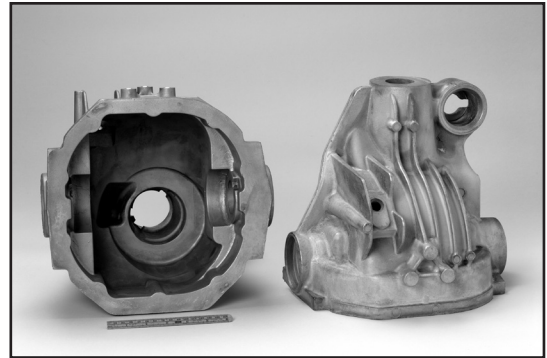

Aluminum

Part Name: Beta Crankcase
Right & Left
Application: Motorcycle
Part Weight: 16.8 lbs.
Alloy: 383
Comments: These net-shape, complex castings were converted from the permanent mold process to meet stringent specifications of improved quality, pressure tightness, cosmetic appearance, higher volume and cost reductions.
Customer: Harley-Davidson

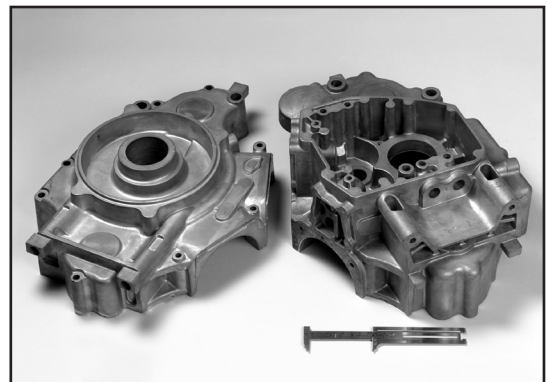

Casting Examples

Aluminum

Part Name: Scooter Monocoque Frame
Application: Honda Scooter Super Sport
Part Weight: 23.4 lbs.
Alloy: JIS ADC12; 383 equivalent
Comments: Previously fabricated from steel sheet stamping and pipes. Die casting provided weight savings and cost reduction.
Customer: Honda R&D Co., Ltd.



Aluminum

Part Name: Rear Wheel Drive Northstar Block Casting
Application: Rear Wheel Drive Northstar Engine
Part Weight: 79.83 lbs.
Alloy: A380
Comments: —
Customer: GM Powertrain

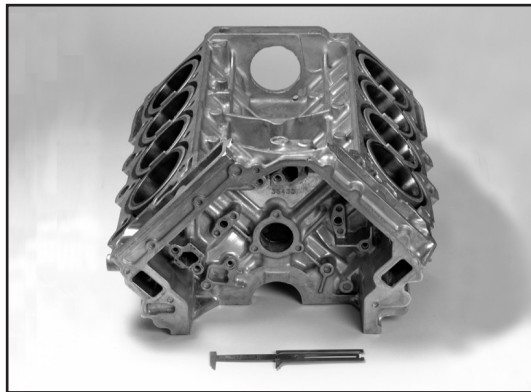

Aluminum

Part Name: Power Conditioning Module Chassis
Application: Computer/Electronics
Part Weight: 2.3 lbs.
Alloy: 380
Comments: Originally machined from a roughly shaped ingot, this chassis gained significant cost savings after being converted to an aluminum die casting.
Customer: Novatel Wireless Technologies, LTD

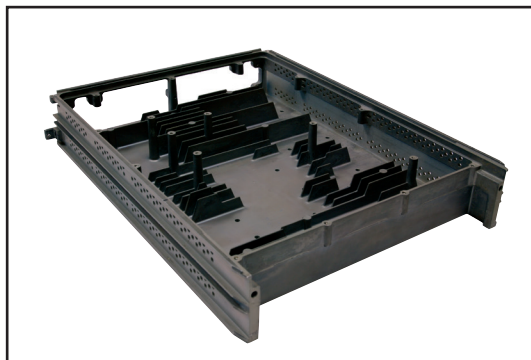

Casting Examples

Aluminum

Part Name: Aluminum MMC Brake Drum

Application: Commercial, Military, and Special Vehicles

Part Weight: 38.5 lbs.

Alloy: A356.2

Comments: Originally produced in cast iron. A unique horizontal squeeze cast process allowed a selectively placed ceramic preform to be infiltrated, creating a selectively reinforced, Metal Matrix Composite (MMC) aluminum brake drum. The new brake drum weights at least 45% less.

Customer: Century 3+ Inc.



Aluminum

Part Name: Automotive AWD Clutch Housing

Application: Automotive

Part Weight: 2.4 lbs.

Alloy: ADC12-T5

Comments: Originally produced as a multi-step forged steel housing, but this part was successfully converted to an aluminum squeeze casting. The new squeeze cast design incorporated 33 spline teeth with 0.1 degree draft. A significant mass reduction was obtained resulting in better fuel efficiency and reduced inertia for improved all wheel drive engagement response time.

Customer: Borg Warner TTS, PTC



Aluminum

Part Name: RWD Transmission

Application: Automobile Industry

Part Weight: 37.4 lbs.

Alloy: A380

Comments: Utilizes a unique process, involving 2 cast-in steel tubes, which have to be inserted in the ejector die and maintain location.

Customer: Chrysler

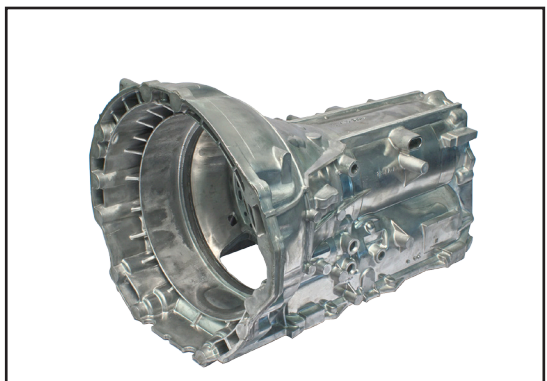

Casting Examples

Magnesium

Part Name: Frame
Application: Novatel Expedite Modem
Part Weight: 0.01 lbs.
Alloy: AZ91D
Comments: Converted from a plastic part. The magnesium casting eliminated a plastic part sandwiched between two metal plates and held together with self tapping screws, resulting in cost savings to the customer.
Customer: Novatel Wireless Technologies, LTD

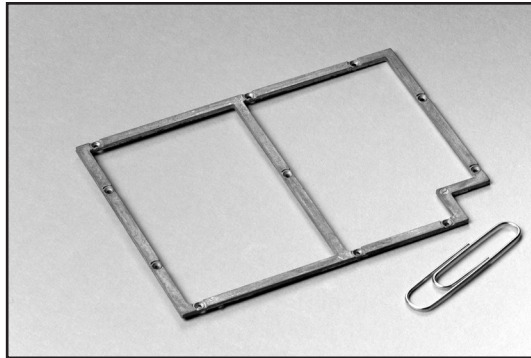

Magnesium

Part Name: Head Node
Application: Mountain Bike
Part Weight: 0.22 lbs.
Alloy: AZ91D
Comments: Originally designed as two aluminum investment cast parts, this unique die cast mag design and application yields a 30% weight savings, part and assembly cost savings, better consistency in impact and fatigue and better performance.
Customer: Cannondale



Magnesium

Part Name: Fishing Reel
Application: Ardent XS Fishing Reel
Part Weight: 31.3 grams
Alloy: AZ91D
Comments: Converted from plastic & die cast aluminum components. Complex geometry & varying wall thickness. Tooling uses 3 slides to form entire exterior of part. Tight tolerance machining of bores and surfaces for mating components. 100% made in USA (Components & Assembly).
Customer: Marsh Technologies, Inc.



Casting Examples

Magnesium

Part Name: Clutch Cover
Application: All Terrain Vehicle Clutch
Part Weight: 0.44 lbs.
Alloy: AZ91D
Comments: A conversion from aluminum die casting to magnesium die casting resulted in a weight reduction of 45% and a significant cost reduction by eliminating machining.
Customer: Polaris Industries, ATV Div.

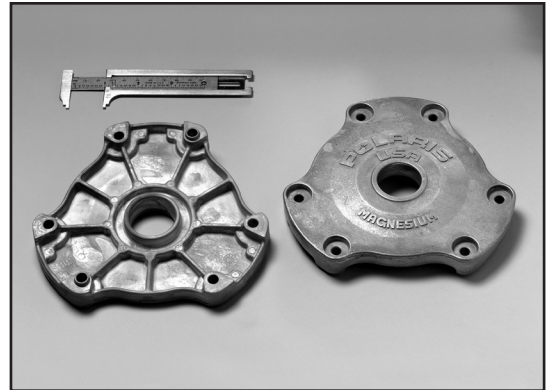

Magnesium

Part Name: Camera Assembly
Application: Digital Camera
Part Weight: 0.48 lbs.
Alloy: AZ91D
Comments: Originally designed as aluminum investment cast parts, the design complexity and required precision mandated a transition to magnesium die cast parts.
Customer: Eastman Kodak



Magnesium

Part Name: Hand-Held Computer Housing
Application: Hand-Held Computer
Part Weight: Over 0.5 lbs.
Alloy: AZ91D
Comments: —
Customer: Telxon Corporation



Casting Examples

Magnesium

Part Name: Gear Case Housing Assembly

Application: Automatic Power Pruner

Part Weight: 0.64 lbs.

Alloy: AZ91D

Comments: Magnesium was chosen for its strength and low weight for this application over plastic and aluminum. Bearing diameter tolerances of 0.001" are required and eliminate machining and masking cost.

Customer: Echo



Magnesium

Part Name: Lock Housing

Application: SUV Tilt Steering Column

Part Weight: 2.02 lbs.

Alloy: AM60B

Comments: This die casting controls the tilt/telescoping features in the steering column and incorporates the ignition switch, shift lever and brake-shift interlock into one casting. In addition to tight dimensional control, the higher elongation in AM60B alloy provides good crash energy management.

Customer: Visteon/Ford

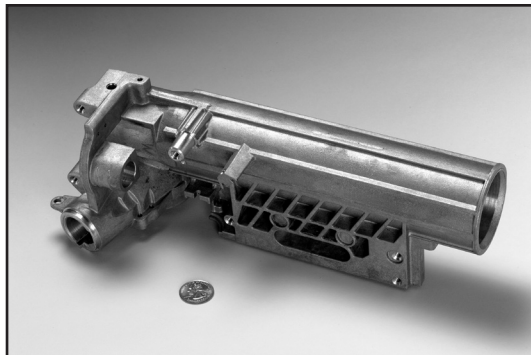

Magnesium

Part Name: Fairing Support Bracket

Application: Buell 1125R Superbike

Part Weight: 2.71 lbs.

Alloy: AZ91D

Comments: This bracket provides support for the motorcycle's instrument cluster, windshield/cowling, direction signals and rearview mirror with increase capacity and a cost savings of approximately 26%.

Customer: Buell Motorcycle Co.



Casting Examples

Magnesium

Part Name: Seat Back and Cushion
Application: Luxury Car Seat Back and Cushion
Part Weight: —
Alloy: AM60B
Comments: —
Customer: —

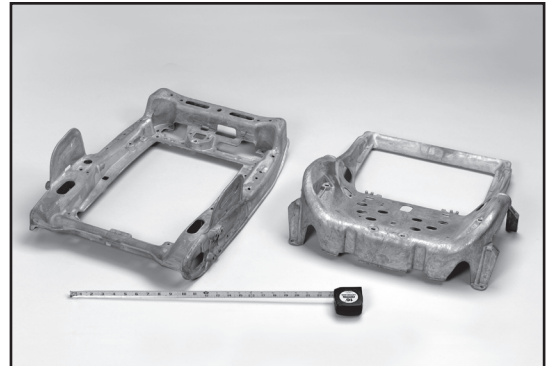

Magnesium

Part Name: Vehicle Lift Gate Inner Panel
Application: Automotive
Part Weight: 18 lbs.
Alloy: AM60
Comments: Replacing a stamped steel assembly, this large die cast magnesium lift gate reduced weight, added design flexibility and reduced assembly time through the integration of various components. The die cast lift gate is 54 x 52 inches.
Customer: Ford Motor Co.

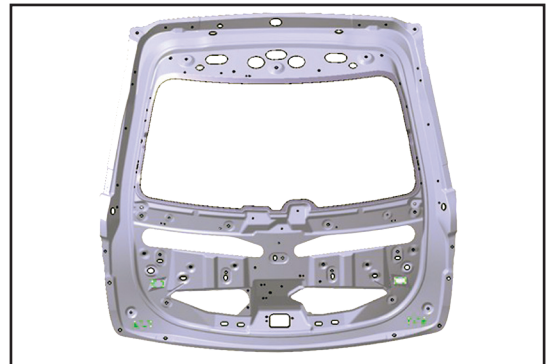

Magnesium

Part Name: Cross Car Beam for Instrument Panel
Application: General Motors Medium Duty Trucks
Part Weight: 21.5 lbs.
Alloy: AM60B
Comments: An example of maximizing the die casting process, machine and die to obtain substantial cost savings. The improvements resulted in weight savings & cost reductions through decreased material, downtime, and elimination of machining/repair.
Customer: General Motors Truck

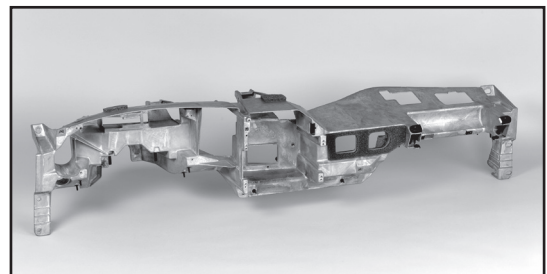

Casting Examples

Magnesium

Part Name: Oil Tank

Application: Snowmobile

Part Weight: 2.03 lbs.

Alloy: AZ91D

Comments: This magnesium oil tank replaces one that was a stamped aluminum and brazed assembly. The case is comprised of 3 separate magnesium die castings. It is lighter and more tunable than the aluminum it replaces.

Customer: Arctic Cat Inc.

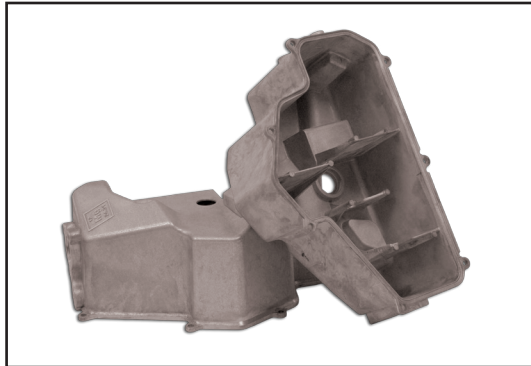

Magnesium

Part Name: SAWZALL Gear Case Assembly

Application: Power Tool

Part Weight: .293 lbs.

Alloy: AZ91D

Comments: Met customer requirements of eliminating machining and reducing cost of similar aluminum castings. Magnesium die casting holds dimensional tolerances that eliminate the need to machine.

Customer: Milwaukee Electric Tool Co.



Casting Examples

Zinc

Part Name: Knot
Application: Marketing
Part Weight: 5.5 Grams
Alloy: ZP5
Comments: This item's shape has never been industrially manufactured and displays ingenious part and tooling design.
Customer: Nyrstar

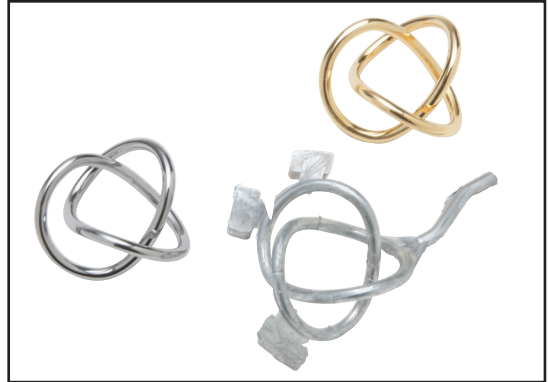

Zinc

Part Name: Bracket
Application: Electronics Enclosure
Part Weight: 15.42 Grams
Alloy: Zamak No. 3
Comments: Converted from a machined aluminum alloy resulting in cost savings. The part is cast to net-shape thereby totally eliminating any machining.
Customer: —

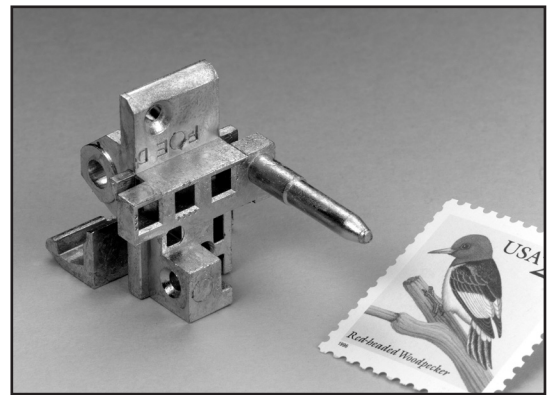

Zinc

Part Name: Faucet Handle
Application: Two Handle Lavatory Faucet
Part Weight: 119 Grams
Alloy: Zamak No. 3
Comments: Major cost savings were achieved from tooling changes, which eliminated trimming, reduced polishing the parting line and machining operations.
Customer: Delta Faucet Company



Casting Examples

Zinc

Part Name: Connector
Application: "TERA" Connector
Part Weight: 0.4 oz.
Alloy: Zamak No. 3
Comments: Die casting offered superior EMI shielding and mechanical integrity at a favorable cost.
Customer: Siemon Company

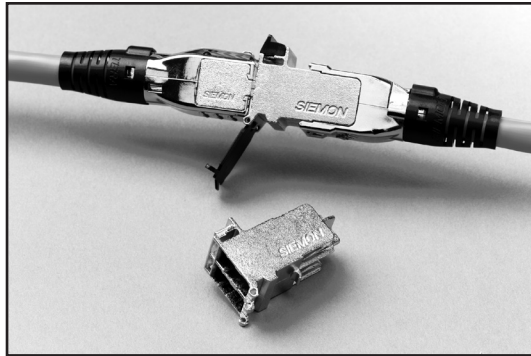

Zinc

Part Name: Kitchen Faucet Hub
Application: Pull-Out Faucet
Part Weight: —
Alloy: Zamak No. 3
Comments: —
Customer: Delta Faucet Company



Zinc

Part Name: Fuel Fitting
Application: Dragon Fly™ Cook Stove
Part Weight: 0.5 oz.
Alloy: Zamak No. 3
Comments: Originally designed as an assembly of three screw-machined components. Converting the component to die cast Zamak 3 provided a cost reduction and allowed for the streamlining.
Customer: Mountain Safety Research

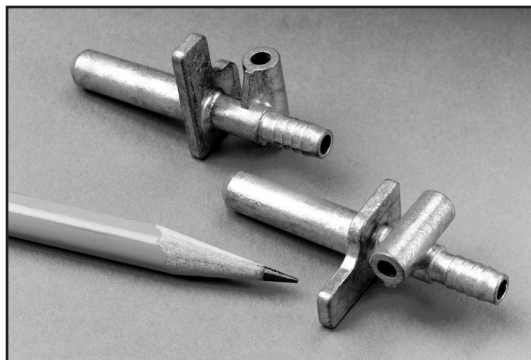

Casting Examples

Zinc

Part Name: Reverse Valve Casting
Application: Snap-On Tools
Part Weight: 1.06 oz.
Alloy: Zamak No. 5
Comments: Exceedingly complex, high tolerance die casting produced in high volumes & requiring minimum machining. Zinc die casting selected over powder metallurgy, machining & metal injection molding because of lower production costs. 50 mils to 230 mils casting thickness & a stepped hole (to a final ID of 0.3000") extending the length of the cylinder with minimum draft.
Customer: Vic Royal

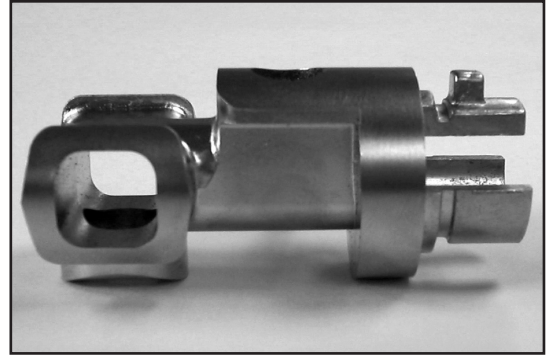

Zinc

Part Name: Casket Arm
Application: Casket
Part Weight: 3.5 oz.
Alloy: Zamak No. 3
Comments: This precisely cored zinc die casting provides the right amount of friction with the hinge to allow the lift bar to remain in the position it was last set. Was a steel stamping.
Customer: Vic Royal

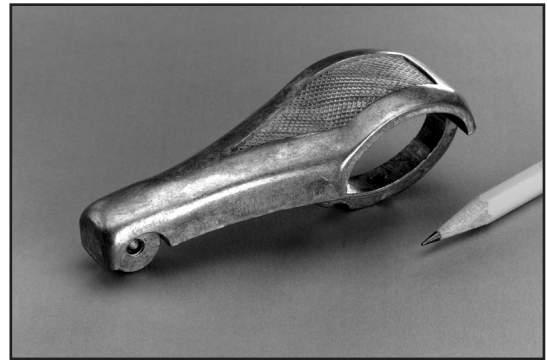

Zinc

Part Name: Display Frame Component
Application: Store Display Unit
Part Weight: 26.16 oz.
Alloy: Zamak No. 3
Comments: Conversion from a steel weldment to a die casting resulted in substantial cost savings. The casting is used as the frame for a track running shoe display rack.
Customer: CDC Marketing

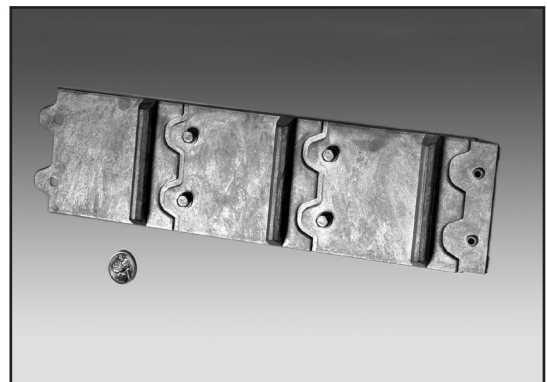

Casting Examples

Zinc

Part Name: Outside Cover
Application: Power Lever Door Lock
Part Weight: 3.0 lbs.
Alloy: Zamak No. 3
Comments: Converted from a permanent mold casting, these die cast parts offer thinner walls, less prep for plating due to the extraordinary surface finish and cost savings (39%).
Customer: Mas-Hamilton Group



Zinc

Part Name: Front Plate L-20
Application: Telecommunications Extension Shelf
Part Weight: 3.53 oz.
Alloy: Za4Cu1
Comments: New part for mounting optical and electrical cartridges. Challenge of fill very thin walls and narrow (0.2 mm) flatness tolerance. Success related to vacuum technology, die thermal conditioning and precision and sprue runner design.
Customer: ALCATEL ITALIA S.p.A.

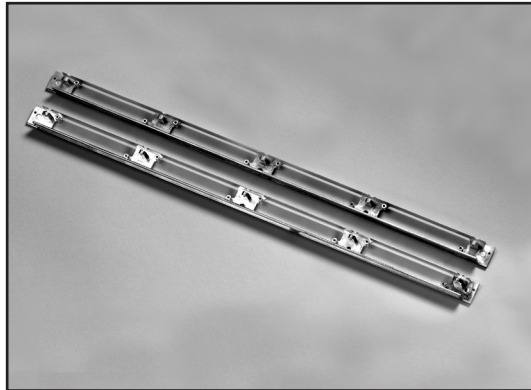

Zinc

Part Name: Connector Housing
Application: Fiber Optic Transceiver
Part Weight: 0.19 oz.
Alloy: Zamak No. 2
Comments: Previously produced from multiple machined cast metal or sheet metal fabricated parts, which lacked precision for speedy assembly of components. Cost savings in material, production methods and labor were achieved with the conversion to die casting.
Customer: Agilent Technologies

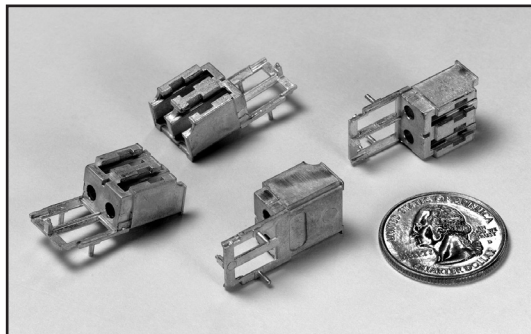

Casting Examples

Zinc

Part Name: Rearview Mirror Mount
Application: Windshild-to-mirror head transition housing
Part Weight: 4.1 oz.
Alloy: Zamak No. 5
Comments: The part was designed around the mirror mount's humidity sensor for the smallest possible footprint.
Customer: Gentex Corporation

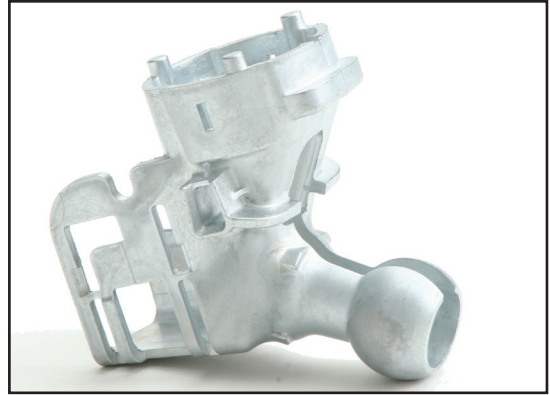

Zinc

Part Name: Steering Wheel Ignition and Lock Housing
Application: Automotive
Part Weight: 13.9 oz
Alloy: Zamak #5
Comments: The ignition and lock housing is a safety-critical component of the automotive steering column. It keeps the steering wheel locked until the car is ready to start and drive.
Customer: Valeo Sisitemas Electronics, SA de CV

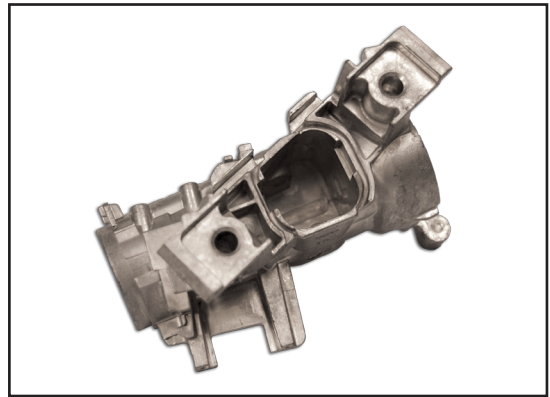

Zinc

Part Name: Headlamp Visor
Application: Harley-Davidson Motorcycle
Part Weight: 2.78 lbs.
Alloy: ZA8
Comments: Combined two parts into one to reduce cost and part numbers. As the center point of the integrated motorcycle handlebar assembly it needs to be functional and aesthetic. Carefully controlled process produces a surface finish conducive for a highly cosmetic chrome plate finish.
Customer: Harley-Davidson



Casting Examples

Zinc

Part Name: Bracket, Camera, ASIC

Application: Infrared Interactive Whiteboard

Part Weight: 0.065 oz.

Alloy Zamak #3

Comments: This zinc die casting replaces an ABS plastic part. It improves the product durability and performance. The casting is used to hold an infrared camera rigidly in place on an interactive whiteboard. This whiteboard connects to a computer and employs infrared light to locate all interactions with the whiteboard.



Customer SMART Technologies

Casting Examples

ZA (Zinc-Aluminum)

Part Name: Tool Housing & Components

Application: Air-Powered Hand Tool

Part Weight: —

Alloy: ZA-8 and ZA-27

Comments: The components for this air ratchet tool consist of two die cast ZA-27 split halves incorporating as-cast “grip” surface embossing, logos and identification and a one-piece ZA-8 air manifold that does not require machining. ZA alloys allowed wall thicknesses of 0.060 inch for the handles and enhanced sound suppression for quieter operation. Previously an assembly of a machined steel head and a cast aluminum handle housing that required extensive machining was used.

Customer: Snap-On

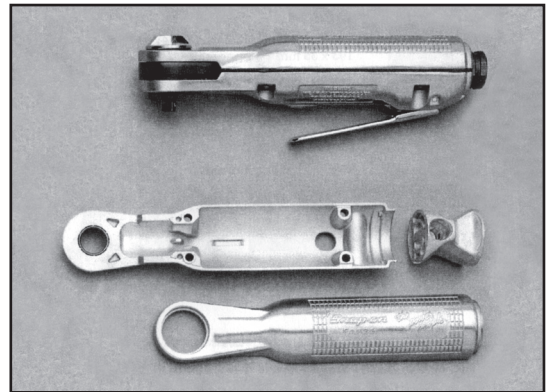

ZA (Zinc-Aluminum)

Part Name: Transmission Shift Selector Tube Unit

Application: Passenger Car & Light Truck

Part Weight: 1.1 lb.

Alloy: ZA-8

Comments: This single die casting replaced a four piece assembly and resulted in an estimated 50% cost savings.

Customer: —

